



Da / From **150**
a / to **1000**
Tonn. / Tons.

PMM

**PRESSA OLEODINAMICA
PER RADDRIZZATURE**

**HYDRAULIC PRESS
FOR STRAIGHTENINGS**

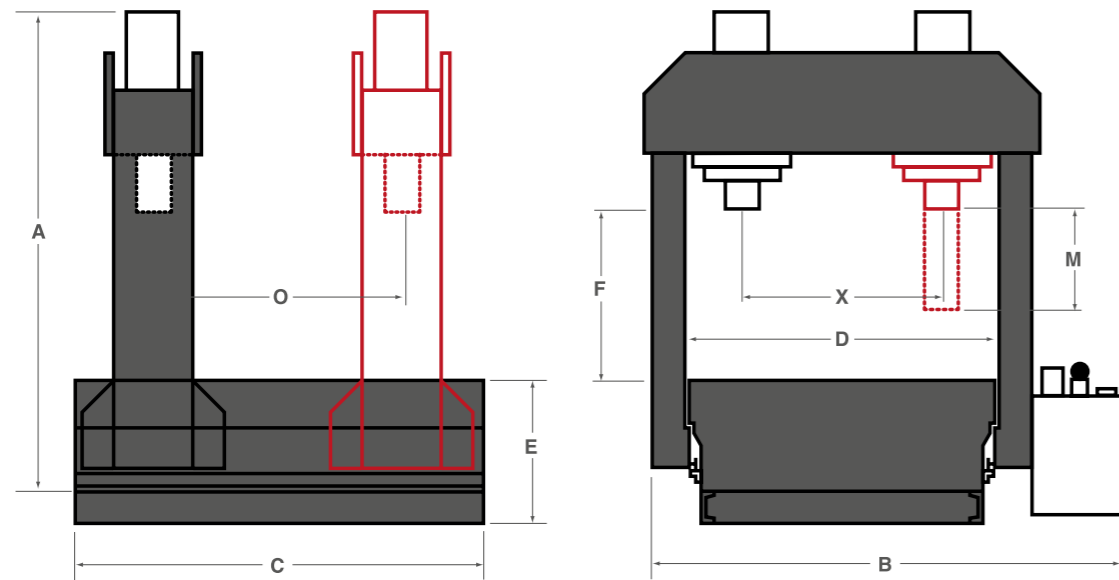

MODELLO Model	Tonn.	A	B	C	D	E	F	M	X	O	VELOCITÀ AVVICINAMENTO mm/sec Approaching speed	VELOCITÀ LAVORO mm/sec Working speed	KW	PESO Weight kg	PESO CON PIANO Weight with plate kg
PMM 150MC	150	2500	2350	2000	1550	750	800	500	1000	1300	20	3	4	4300	5850
PMM 150MD	150	2500	2900	2500	2050	750	800	500	1400	1600	20	3	4	5200	7750
PMM 200MC	200	2600	2400	2000	1550	750	800	500	1000	1300	20	2	4	5000	6600
PMM 200MD	200	2600	2950	2500	2050	750	800	500	1450	1600	20	2	4	6000	9000
PMM 200ME	200	2600	3550	3000	2550	750	800	500	1900	2000	20	2	4	8400	12800
PMM 300MD	300	2600	3100	3000	2050	700	700	500	1300	2000	20	2	5,5	10100	13600
PMM 300ME	300	2600	3550	4000	2550	700	700	500	1800	2800	20	2	5,5	13400	19150
PMM 300MT	300	2600	4000	5000	3050	700	700	500	2200	3600	20	2	5,5	19200	28800
PMM 400ME	400	2600	4000	4000	2550	700	700	500	1800	2900	20	2	7,5	17000	22700
PMM 400MT	400	2600	4500	5000	3050	700	700	500	2200	3600	20	2	7,5	21000	30100
PMM 500ME	500	3000	5000	5000	2550	700	700	500	1700	3600	18	3	15	32000	42000
PMM 600ME	600	3000	5000	6000	2550	700	700	500	2200	4600	18	3	22	35000	46000



Sicmi si riserva il diritto di apportare modifiche eventuali senza impegno di aggiornare il presente prospetto.
Sicmi reserves all rights to make any changes without obligation to update this specification.



PRESSE OLEODINAMICHE

A MONTANTE E CILINDRO MOBILE

**MOVABLE STANCHION
AND CYLINDER**



PRESSE OLEODINAMICHE

SICMI S.R.L. - S. QUIRICO 43018 SISSA - TRECASALI (PARMA) ITALY VIA
IV NOVEMBRE, 35 - TEL. +39 0521 873346/44 - FAX +39 0521 872952
info@sicmi.it - www.sicmi.it

PMM

PRESSA OLEODINAMICA PER RADDRIZZATURE

HYDRAULIC PRESS FOR STRAIGHTENINGS

CARATTERISTICHE

Montante mobile con movimento longitudinale OLEODINAMICO, cilindro mobile con movimento trasversale OLEODINAMICO.

UTILIZZO

raddrizzature di lamiere e carpenteria; curvature; collaudi vari.

COMANDI

LEVE e PULSANTE coordinati, rispondenti alle normative CE.

OPTIONAL

Piano di lavoro saldato e alesato per la superficie del bancale. Comando a pulsantiera tipo pensile rotazione 180°. Impianto con elettrovalvole Rexroth e CPU Siemens. Pulsantiera radiocomandata a doppi pulsanti. Impianto con elettrovalvole Rexroth e CPU Siemens. Cilindretti di sollevamento inseriti nel piano. Comandi con selettore sul pensile per salita/discesa. Controllo DIGITALE con encoder e visualizzatore quote inserito nel quadro elettrico. Pannello comandi su braccio con rotazione a 180°. Doppia velocità (rapido e lento) per i movimenti del cilindro e del montante. Dispositivo anti-rotazione stelo. Scambiatore di calore aria/olio con valvola di decompressione.

FEATURES

Movable stanchion with longitudinal HYDRAULIC displacement, movable cylinder with transversal HYDRAULIC displacement.

USE

Sheet and metalworks straightening, bendings, different testings.

CONTROLS

By coordinate LEVERS and PUSHBUTTON, following to "CE" norms.

OPTIONALS

Welded and bored plate for the table surface. Control by hanging keyboard with 180° rotation. System with Rexroth solenoid valves and CPU Siemens. Radio-controlled keyboard with double pushbuttons. System with Rexroth solenoid valves and CPU Siemens. Small cylinders fitted in the table Controls with selector on the hanging for upstroke/downstroke. DIGITAL control with encoder and quote viewer in the electric board. Controls panel on the bracket with 180° rotation. Double speed (fast and slow) for the movements of cylinder and stanchion. Device for anti-rotation of the shaft Air / oil heat Exchanger decompression valve.

Comandi manuali con 3 leve posizionate sulla centralina. Pulsante per comando 2 mani.

Manual control by three levers placed on the hydraulic unit. Pushbutton for two hands control.



RADDRIZZATURA
LAMIERE E CARPENTERIA

STRAIGHTENING SHEET METAL
AND CARPENTRY

2 CILINDRI MOBILI
CONTROLLO DIGITALE DELLA CORSA

2 MOVABLES CYLINDERS.
DIGITAL CONTROL OF THE STROKE.



DOPPIO MONTANTE PER LAVORAZIONI
CONTEMPORANEE

DOUBLE STANCHION FOR WORKING
DONE AT THE SAME TIME



SICMI

PRESSE OLEODINAMICHE